

Dorm Connections:

Each dorm room is equipped with a single network connection for student computers. Students wishing to connect more than 1 computer per room may purchase a hub and 3 network cables from the Campus Bookstore or any local computer retail store. (Use only hubs or switches, **not** routers!) One cable will run from each pc to the hub and one will run from the hub to the wall jack. Make sure to measure the distances from the wall jack to the hub and from the hub to the computers in order to buy the appropriate lengths of cable.

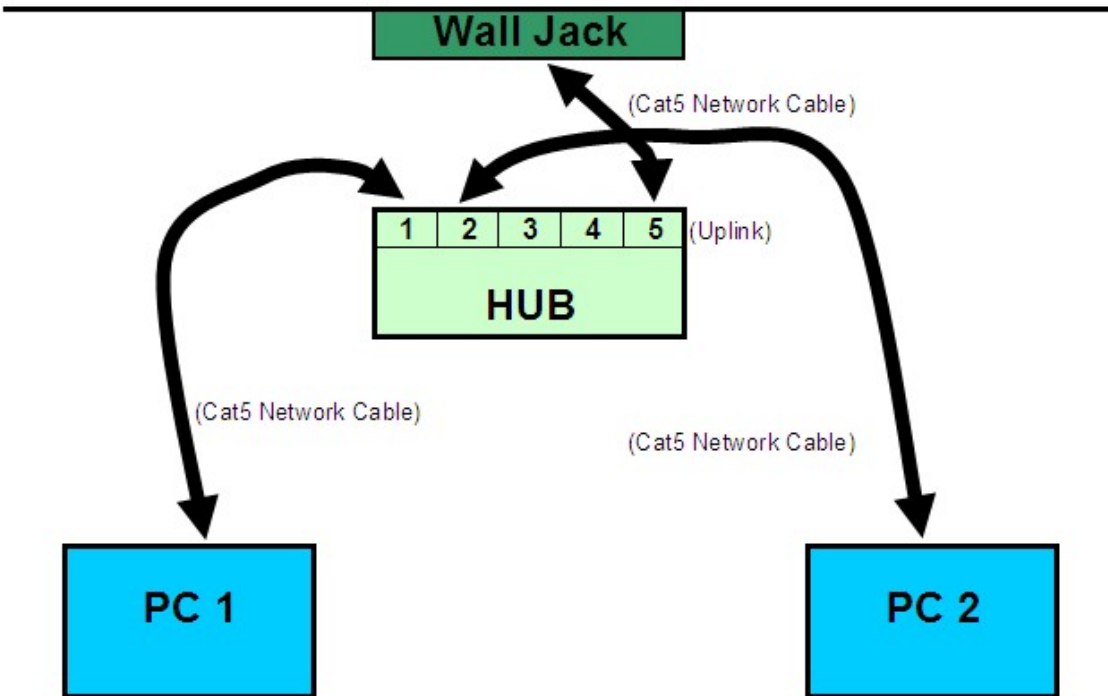

It is not necessary to install the Novell client on your computer to access the Internet. If your network card is installed, you may connect to the Internet by following these steps:

Windows 98

1. Right-click on Internet Explorer and select Properties.
2. Click on the Connection tab and then on the Setup button.
3. Select "I want to set up my Internet connection manually..." and click on Next.
4. Select "I connect through a local area network [LAN]" and click on Next.
5. Leave the check mark on "Automatic discovery of proxy server" and click on Next.
6. Select "No" for Internet mail account and click on Next.
7. Click Finish.

Windows XP

1. Right-click on Internet Explorer and select Internet Properties.
2. Click on the Connection tab and then on the Setup button.
3. Click Next and select "Connect to the Internet."
4. Select "Connect using a broadband connections that is always on."
5. Click Finish.

This will allow you to access the Internet and [My.SNU](http://my.snu.edu) which provides **email**. It will also allow access to network drives such as your personal F: drive, which contains 25 MB of file space, or the group G: drive, which contains shared files used for classes through NetStorage at <http://my.snu.edu>